

HALLER

苏州哈勒智能装备有限公司
Suzhou Haller Intelligent Equipment Co.,Ltd.

地址: 苏州市相城区富元路富阳工业坊10号厂房 215131
电话: +86 (0) 512 6983 3910
邮箱: info@szhaller.com
网址: www.szhaller.com

Add: No.10, FuYang Industrial Park, FuYuan Road, XiangCheng District,
215131, Suzhou, China
Tel: +86 (0) 512 6983 3910
Email: info@szhaller.com
Web: www.szhaller.com



版本号 VERSION: 202503

HALLER
M1+

5轴数控刀具磨床
5-axis CNC Tool Grinding Machine

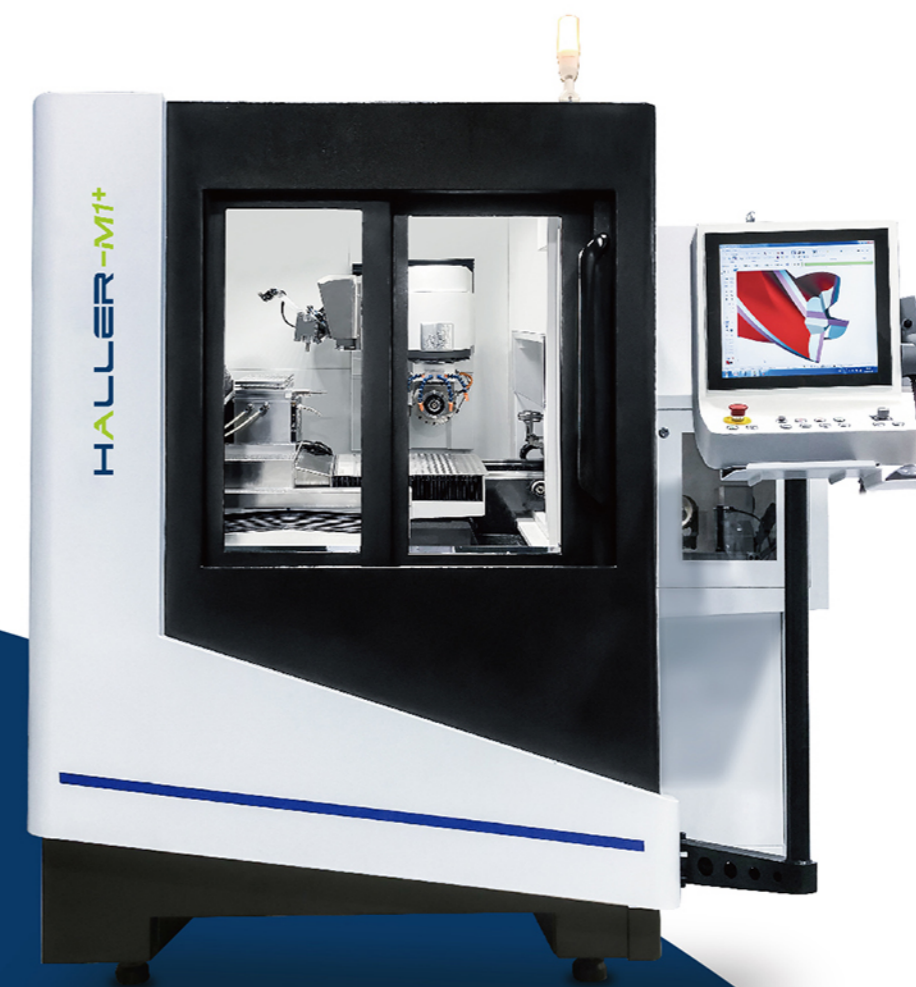

苏州哈勒智能装备有限公司
Suzhou Haller Intelligent Equipment Co.,Ltd.

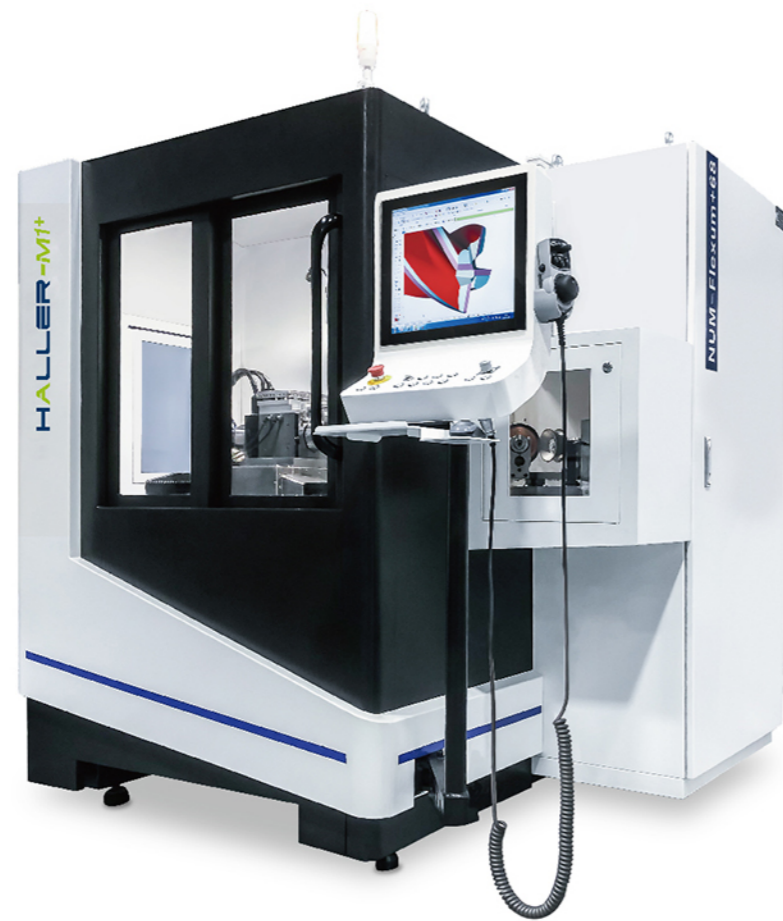

HALLER-M1+

哈勒智能是一家高精度数控机床的制造商，致力于为客户提供刀具和零件加工解决方案。我们拥有不同系列的数控机床，如工具磨床、凸轮磨床、医疗骨锉磨床和齿轮倒角机床等，广泛应用于汽车、航空、电子、医疗等各个领域。

我们不仅可以为客户提供多元化的解决方案，专业的应用培训，优质的售后服务，还可以帮助客户解决加工难点，为客户创造更多价值。

Haller Intelligent is a manufacturer of high precision CNC machines, providing solutions of tools and parts processing. We have different series of CNC machines, such as tool grinding machines, cam grinding machines, medical bone rasper grinding machines, gear chamfering machines, widely used in industry fields including automobile, aviation, electronics, medical etc.

We can not only provide customers with diversified solutions, professional application training, and high-quality service, but also can help them solve processing problems and create more value for customers.

内部概览

Inside Overview

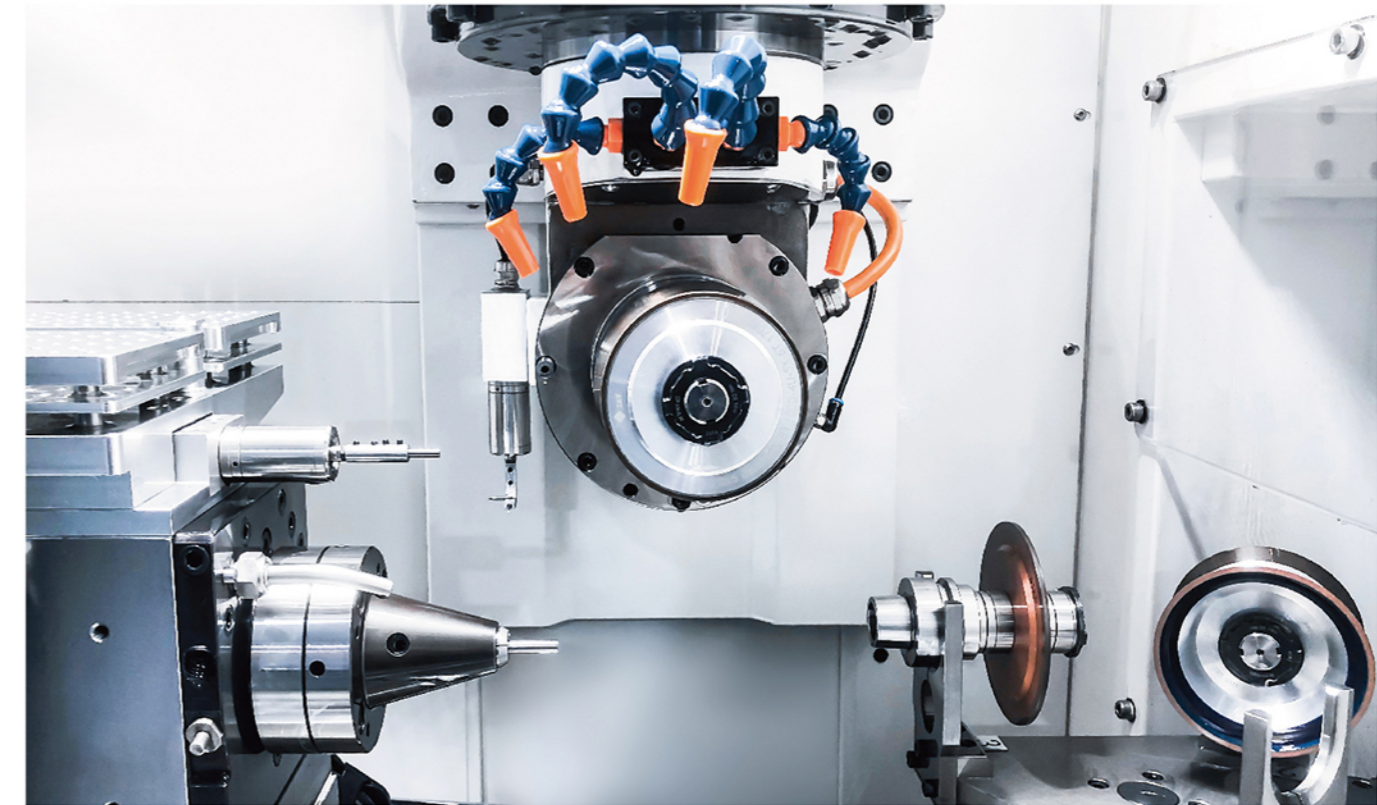

功能优势

Function Advantages

- 机床外形精致美观，床身小巧节省空间。
- 天然花岗石床身具有良好的减震性和耐热性，硬度高，耐磨性强。
- 独特的结构设计，行程短，加工效率高。
- X、Z轴高精度直线电机，超高推力密度；配有全闭环高精度直线光栅尺，稳定性持久。
- 单头磨削主轴，加工快捷，稳定性高；配有永磁电机，扭力大，低损耗。
- 工件、砂轮全方位自动在线测量系统高效准确，保证了加工刀具的稳定性。
- 采用全球领先的NUM控制系统与NUMROTO磨削软件，简单易学。
- 个性化操控面板，直观简便。

- The machine looks beautiful, exquisite and space-saving.
- Natural granite machine bed has a good shock absorption and heat resistance ability, high-hardness and strong anti-abrasion property.
- The unique structure design is in short travel, bringing high processing efficiency.
- X, Z axis high precision linear motors have super-high thrust density, equipped with full closed-loop high precision linear scale, durably stable.
- Single-ended grinding spindle, fast processing, high stability, equipped with PM motor of high torque and low power loss.
- Automatic full-directionally internal measuring system for both work piece and grinding wheel are efficient and accurate, which ensure the tool machining stability.
- The worldwide leading NUM control system and NUMROTO grinding software are easy to learn.
- Individualized control panel is visually simple.

高精度直线电机

High-precision Linear Motor

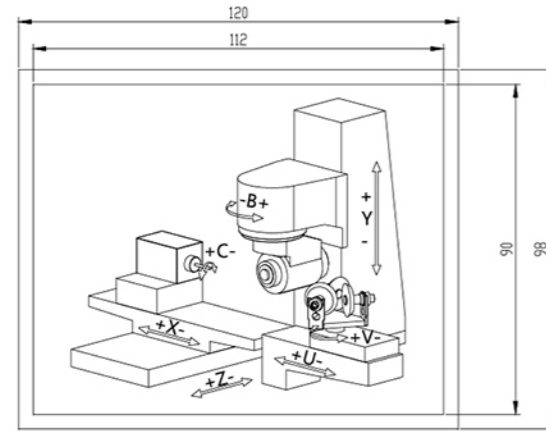

直线光栅尺
Linear scale



X、Z轴直线电机，具有超高推力密度，低顿力，配有海德汉全闭环高精度直线光栅尺，直线光栅尺具有测量方向上的高刚性，热特性好等特点，全闭环控制模式能消除潜在的多个误差源，从而保证了机床高精度定位和高速加工时的稳定性，且长期持久。Y轴采用高扭矩输出NUM伺服电机，可配直线轴光栅尺。

The X and Z axis linear motors with super-high thrust density; equipped with HEIDENHAIN closed-loop high precision linear scale. The linear scale has the characteristics of high rigidity in measurement direction and good thermal property. The full-closed-loop control mode can eliminate potential multiple error sources, thus ensuring the stability of high precision positioning and high speed machining during tool machining in long term stability. Y axis is with high-torque output NUM servo motor, optionally equipped with linear scale.

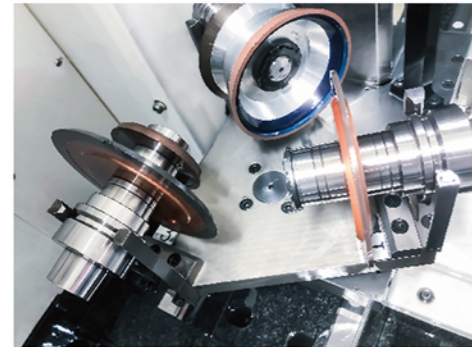

可编程3工位砂轮库

Programmable 3-package wheel changer

3工位砂轮库，机内自动更换砂轮，最大砂轮直径125mm。

3-package wheel changer, automatically change the grinding wheel inside machine, wheel max diameter 125mm.

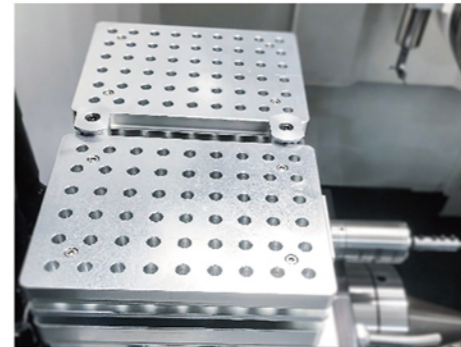

料盘

Loader

更换便捷，不同规格的工件均通用，不需要重新设定机械手位置。单个料盘70支一批，中等批量加工，避免因钨粉沉积导致刀具精度受影响。

Easy to replace, universal use of work pieces in different sizes to avoid robot repositioning. 70pcs per tray, medium batch production to avoid the tool run out caused by tungsten powder deposition.

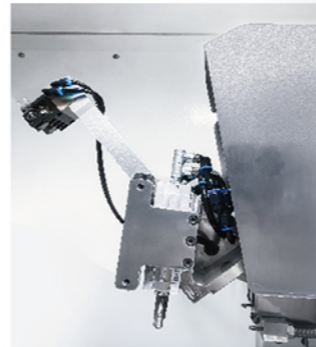

机械手

Pick up robot

自动上下料，灵活高效，可实现无人化生产。

Automatic loading and unloading, highly flexible and efficient, realize unmanned production.

SK40工件轴

Workpiece Axis

SK40工件轴(C轴)采用高扭矩直驱电机，分辨率可达0.0001°，最高转速1000rpm，为在线外圆磨削提供可能。

SK40 workpiece axis (C axis) uses torque motor with resolution of 0.0001°, maximum speed of 1000rpm, making it possible for cylindrical grinding.

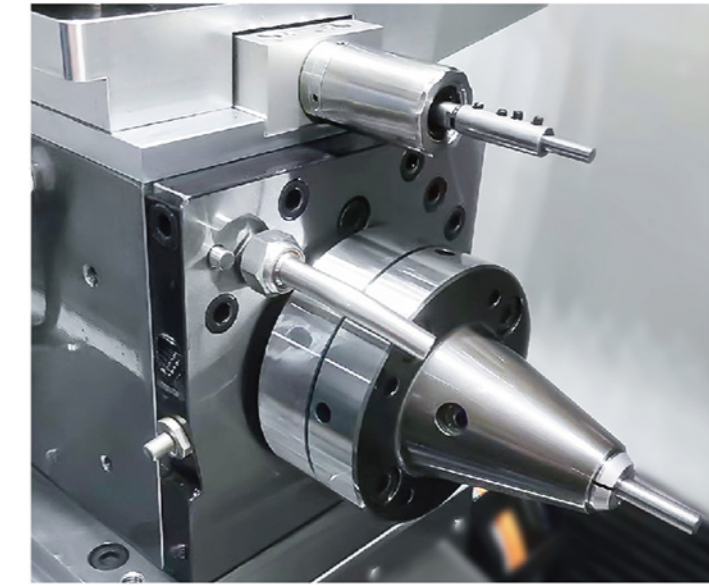

工件测量系统

Workpiece measuring system

在线对工件进行迅速定位，在刀具加工过程中测量并修整工件参数，保证了刀具加工的质量。

The work piece is internally rapid-positioned, and the work piece parameters are measured and adjusted in the process of tool machining to ensure the tool quality.



砂轮测量系统

Grinding wheel measuring system

机床在线测量砂轮参数，迅速便捷，有助于减少机外测量检测时间，避免人工检测错误，准确高效，从而保证刀具加工稳定性，提高加工效率。

Machine automatic internal measurement of grinding wheel parameters, fast and convenient, to helpfully reduce the measuring time outside the machine, avoid manual checking errors, accurately and efficiently, so as to ensure the stability of the tool machining and efficiency is improved as well.

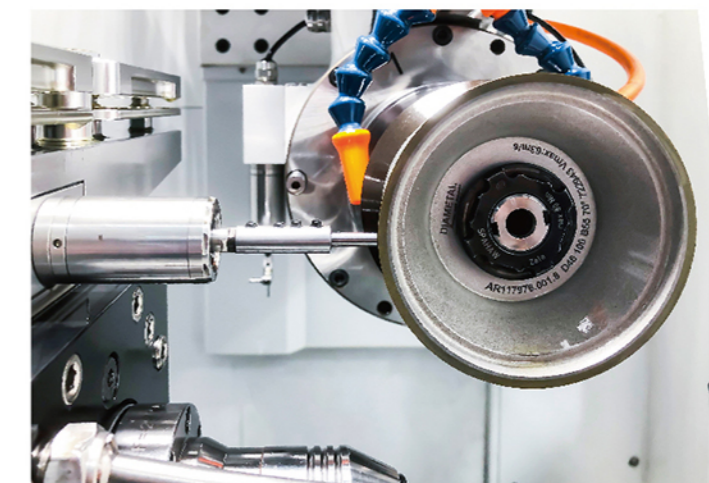

稳定可靠的控制系统

Reliably Stable Control System

NUM-Flexium⁺⁶⁸

- 新一代NUM-Flexium⁺⁶⁸数控轴系统；
- 高分辨率直驱电机；
- 17英寸TFT彩色显示屏, 个性化操控面板, 直观简便；
- 优化设计的电器柜易于修理；
- 通过光纤链接的可旋转操作面板方便操作；
- 直接安装在机床电器柜里的电脑为今后的维护、更换、升级提供了便利从而节省了费用。

- Digital CNC control unit for highest requirement;
- High resolution direct drive motor;
- 17-inch TFT colour display with uniquely simple operating panel;
- Electrical cabinet with optimal arrangement and accessibility for easy servicing;
- Rotatable panel connected via Ether-cut simple for simple operation;
- An office PC can easily be integrated in the electrical cabinet to promote maintenance, rapid replacement and updates without high investment costs.

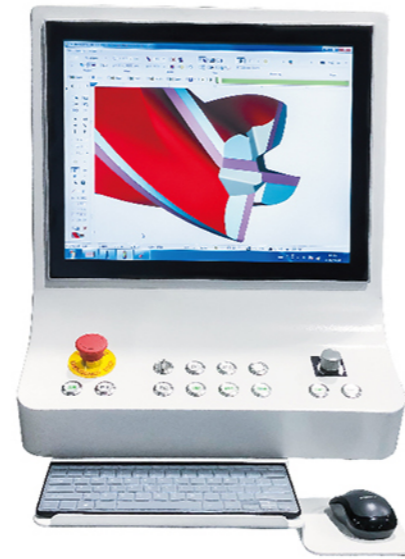

简单的磨削软件

Easy Grinding Software



NUMROTOplus[®]是全球领先的用户软件, 多年来成为高精度刀具磨削中的成功引领者。NUMROTOplus[®]软件简单易学, 普通工人即可在短时间内迅速学会并熟练操作, 大大降低工人培训难度, 为客户降低培训成本。

NUMROTOplus[®] is the worldwide leading user software, successful trendsetter in high-precision tool grinding for many years. NUMROTOplus[®] software is simple and easy to learn, ordinary workers can quickly acquire grinding skills and operate proficiently in a short time, greatly reducing the difficulty of training workers, and reducing training costs for customers.

技术参数

Technical Data

磨削范围 Grinding range	
刀具加工直径范围 Diameter range for tool production	0.5-16mm
最大刀具修磨直径 Max. diameter for tool regrinding	50mm
最大加工长度 Max. processing length	180mm
控制系统 Control System	
CNC 控制部分 CNC control unit	NUM-Flexium ⁺⁶⁸
TFT液晶显示器 TFT liquid crystal display	17英寸 Inch
磨削软件 Grinding software	
NUMROTOplus [®] 铣刀, 钻头, 非标刀具, 3D模拟软件 NUMROTOplus [®] milling cutters, drills, special tools, 3D simulation software	
测量系统 Measurement system	
刀具测量 Tool measurement	3-D 探针 Probe
砂轮测量 Grinding wheel measurement	3-D 探针 Probe
磨削主轴 Grinding spindle	0-8000rpm
主轴最大功率 Max. spindle power	15KW
砂轮 Grinding wheels	
砂轮最大直径 Max. wheel diameter	125mm
3工位砂轮库 3-package wheel changer	NC控制 NC Controlled
每个砂轮连杆可装 Grinding wheels per arbour	1-3片砂轮 1-3 pcs grinding wheels
冷却阀 (程序控制) Cooling via cooling valve(Program-controlled)	2组 2 Valves
砂轮杆接口 Grinding wheel interface	HSK50F
C轴 (工件轴) C-axis (Workpiece axis)	
C轴 C-axis	SK40
工件夹紧系统 Tool clamping system	自动 Automatic
驱动形式 (直驱) Drive(Direct drive)	最大1000rpm 1000rpm max.

冷却方式 Cooling	
主轴 / 工件轴 / B轴 Spindle / Workpiece axis / B axis	集成油冷 Integrated oil cooling
油雾接口 Oil mist interface	Φ 150mm
轴行程 Axis travel	
X轴 X axis	385mm
Z轴 Z axis	330mm
Y轴 Y axis	160mm
速度 (X轴) Speed X axis	20m/min
速度 (Z轴) Speed Z axis	20m/min
速度 (Y轴) Speed Y axis	8m/min
分辨率 (C轴) Resolution C axis	0.0001°
旋转轴 (B轴) Rotation axis B axis	270°
分辨率 (B轴) Resolution B axis	0.0001°
X,Z轴 X Z axis	直线电机 Linear Motors
Y轴 Y axis	NUM伺服电机 NUM servo motor
机床尺寸 Machine dimensions	
长度/宽度/高度 Length/Width/Height	2000mm*2000mm*2260mm
重量 Weight	Appr.4200KG
电源 Power supply	3×400V-50HZ/32A
功率输入 Power input	21KW
压缩空气 Air Supply	≧ 6bar
颜色 Colour	RAL9005/RAL9003

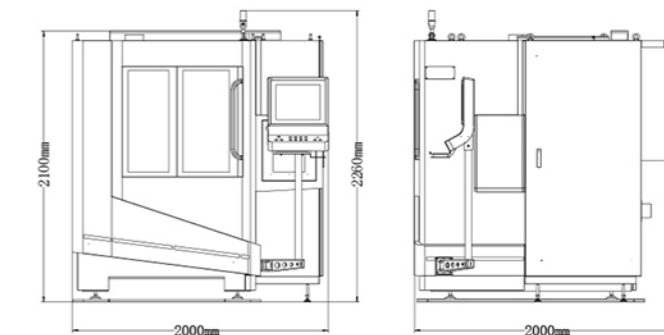

* 哈勒公司保留对技术规格参数修改或升级的权利。
Suzhou Haller reserves the right to modify or upgrade the technical specifications.